

Internal Gear Driven Pump IPZ 1 - HR 5 Standard with 0,30 ccm/RPM

Default Design (Clockwise Shaft Rotation Viewed)

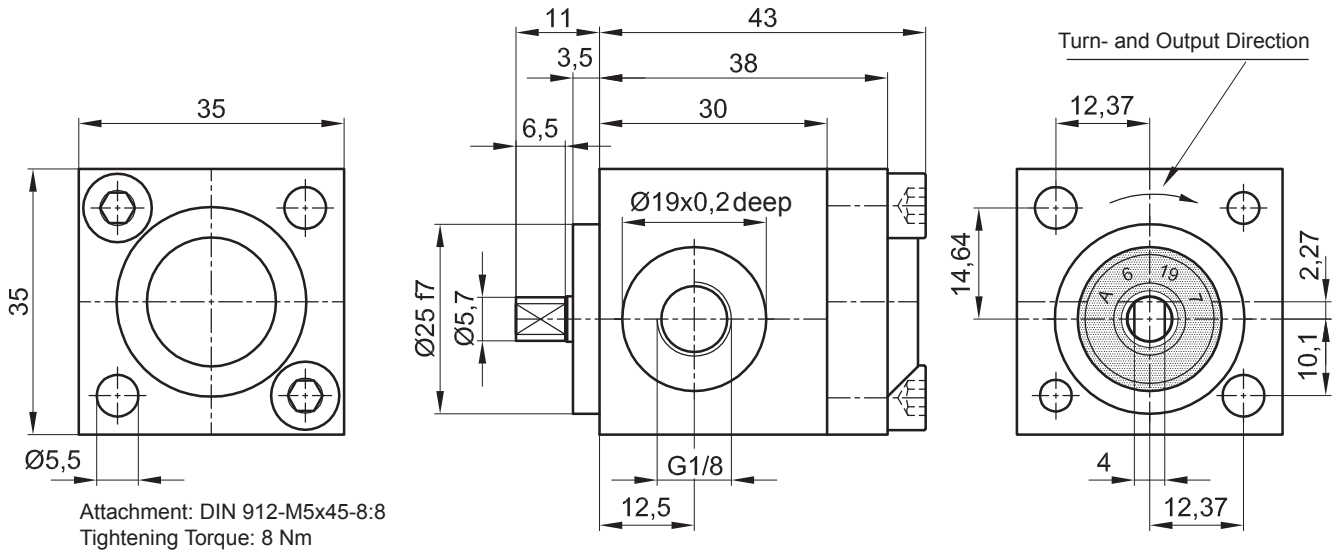

Symbol:



The technical data are based on a viscosity of 46 sq mm/s

ccm/ rpm	Press./bar max.		RPM max.		RPM min.	Mass	Order No.
	P1	P max	Press. P1	Depress.	Press. P1		
0,30	80	120	4000	5000	1000	300 g	10004-142

P1 = Working Pressure max. P max. = Pressure Peak

Working Pressure / bar							
Capacity at 1.500 RPM (l/min)							
Power Consumpt./W at 1.500 RPM							
bar	10	20	40	60	80	100	120
l/min	0,44	0,43	0,42	0,39	0,36	0,32	0,27
Watt	15	30	60	90	120	150	180

Working Pressure / bar							
Capacity at 3.000 RPM (l/min)							
Power Consumpt./W at 3.000 RPM							
bar	10	20	40	60	80	100	120
l/min	0,89	0,88	0,86	0,84	0,80	0,77	0,68
Watt	30	60	120	180	240	300	360

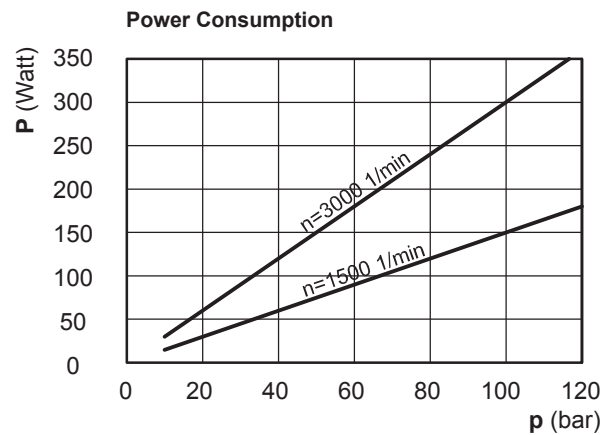
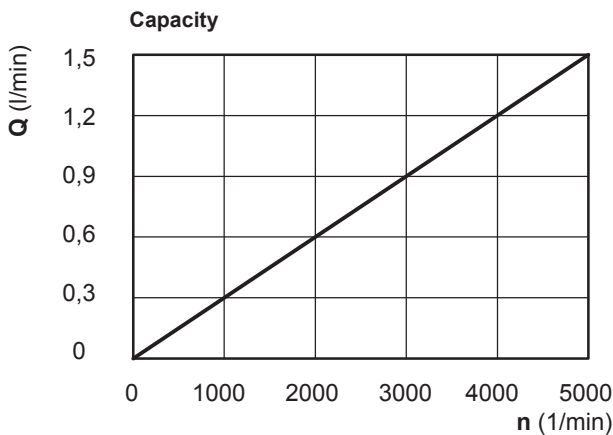

Please specify Pressure, RPM, Temperature, Gain and the Duty Cycle by ordering!



Jung-Fluidtechnik GmbH
Mohrenstrasse 7
D-76275 Ettlingen

Phone +49 (0) 7243-14648
Fax: +49 (0) 7243-17996
E-Mail: info@jung-fluid.de

Data Sheet

IPZ 1 - HR 5
subject to modifications