

# Internal Gear Driven Pump IPZ 1 - HR 2 Standard with 0,12 ccm/RPM

Default Design (Clockwise Shaft Rotation Viewed)

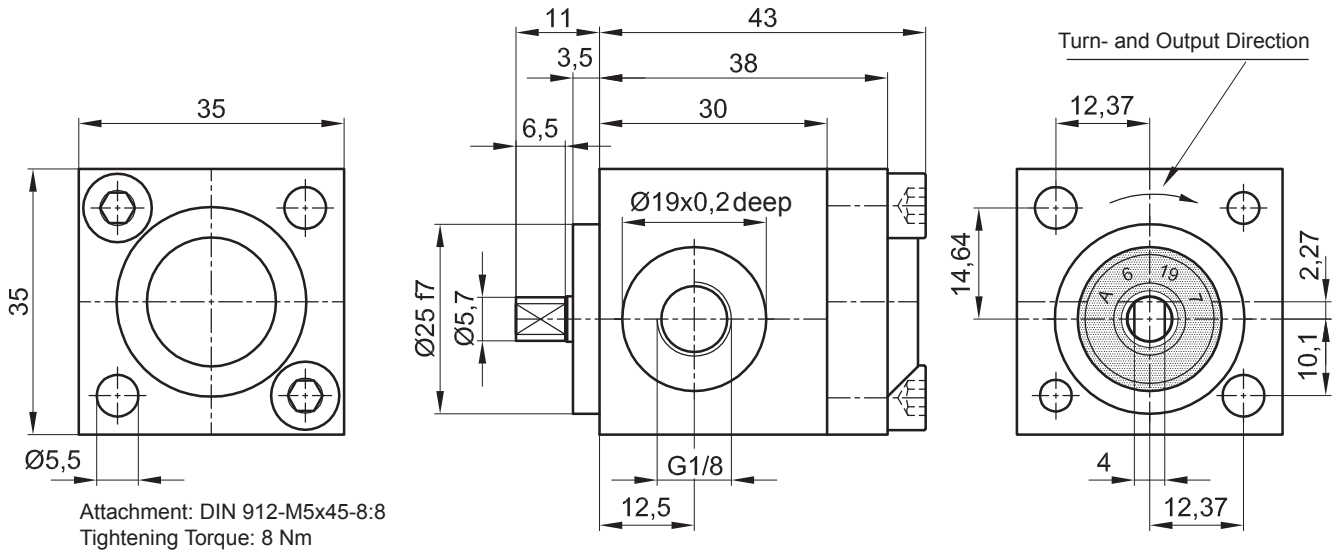

Attachment: DIN 912-M5x45-8:8  
Tightening Torque: 8 Nm

Symbol:



The technical data are based on a viscosity of 46 sq mm/s

ccm/ rpm	Press./bar max.		RPM max.		RPM min.	Mass	Order No.
	P1	P max	Press. P1	Depress.	Press. P1		
0,12	80	120	4000	5000	1000	300 g	10002-142

P1 = Working Pressure max. P max. = Pressure Peak

Working Pressure / bar							
Capacity at 1.500 RPM (l/min)							
Power Consumpt./W at 1.500 RPM							
bar	10	20	40	60	80	100	120
l/min	0,17	0,16	0,15	0,14	0,13	0,11	0,09
Watt	6	12	24	36	48	60	72

Working Pressure / bar							
Capacity at 3.000 RPM (l/min)							
Power Consumpt./W at 3.000 RPM							
bar	10	20	40	60	80	100	120
l/min	0,35	0,34	0,33	0,32	0,31	0,30	0,26
Watt	12	24	48	72	96	120	144

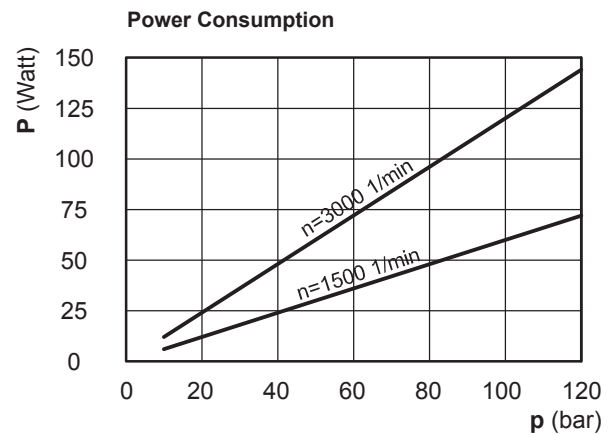
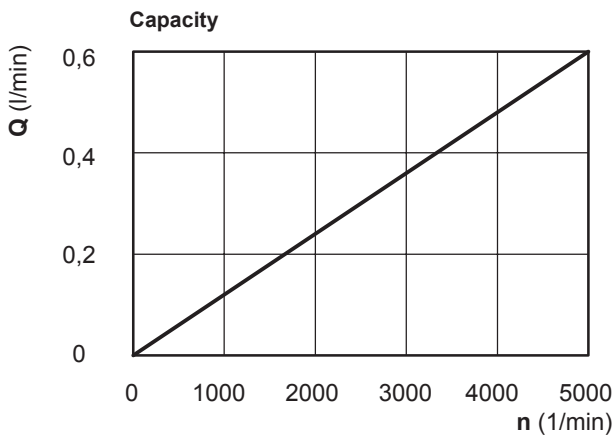

Please specify Pressure, RPM, Temperature, Gain and the Duty Cycle by ordering!



Jung-Fluidtechnik GmbH  
Mohrenstrasse 7  
D-76275 Ettlingen

Phone +49 (0) 7243-14648  
Fax: +49 (0) 7243-17996  
E-Mail: info@jung-fluid.de

Data Sheet

**IPZ 1 - HR 2**  
subject to modifications