

# Internal Gear Driven Pump IPZ 0 - HER 3 Mounting with 0,09 ccm/RPM

Default Design (Clockwise Shaft Rotation Viewed)

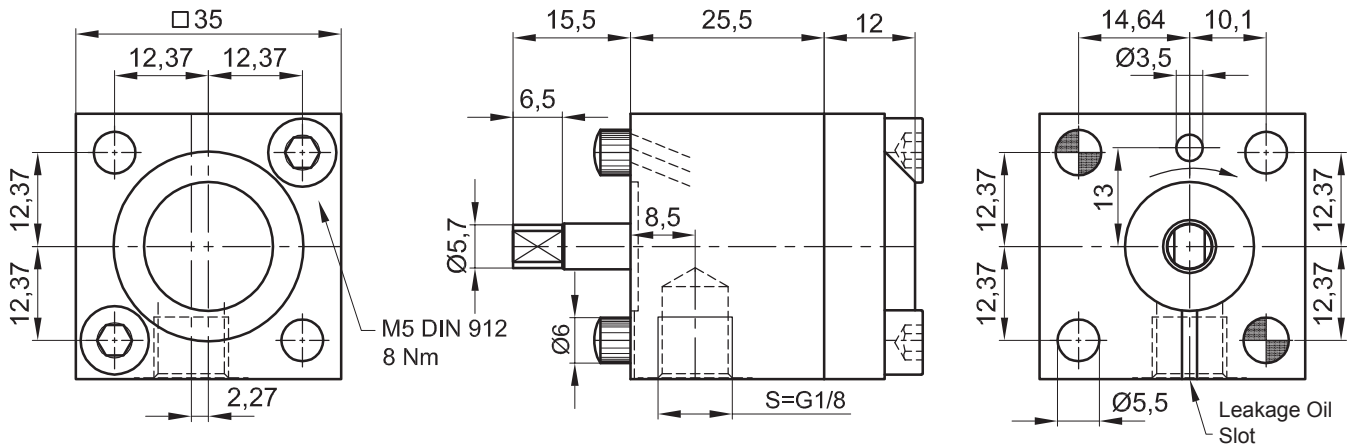

Symbol:



The technical data are based on a viscosity of 46 sq mm/s

ccm/ rpm	Press./bar max.		RPM max.		RPM min.	Mass	Order No.
	P1	P max	Press. P1	Depress.	Press. P1		
0,09	80	120	4000	5000	1000	280 g	10012-141

P1 = Working Pressure max. P max. = Pressure Peak

Working Pressure / bar							
Capacity at 1.500 RPM (l/min)							
Power Consumpt./W at 1.500 RPM							
bar	10	20	40	60	80	100	120
l/min	0,14	0,14	0,14	0,14	0,13	0,12	0,11
Watt	5	9	18	27	36	45	54

Working Pressure / bar							
Capacity at 3.000 RPM (l/min)							
Power Consumpt./W at 3.000 RPM							
bar	10	20	40	60	80	100	120
l/min	0,28	0,28	0,28	0,28	0,27	0,26	0,25
Watt	9	18	36	54	72	90	108

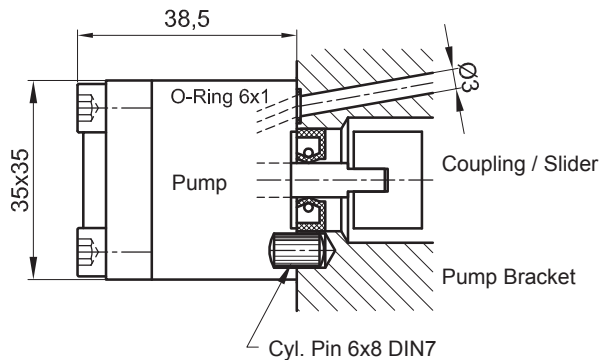
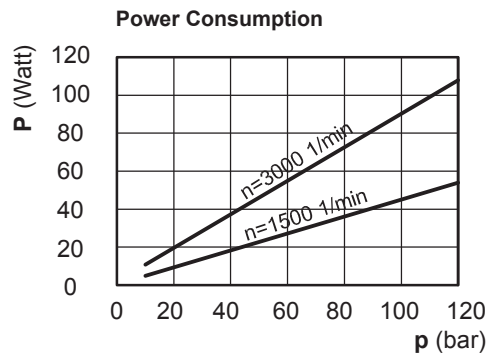
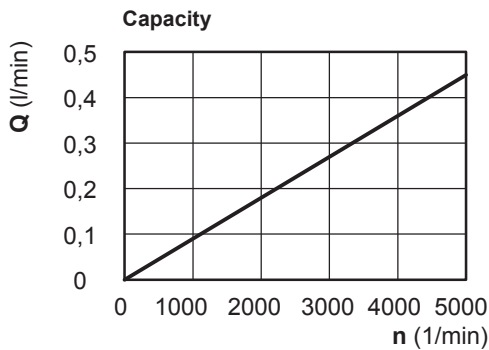

Drawing for Drilling: Pump Attachment (Pump Bracket)

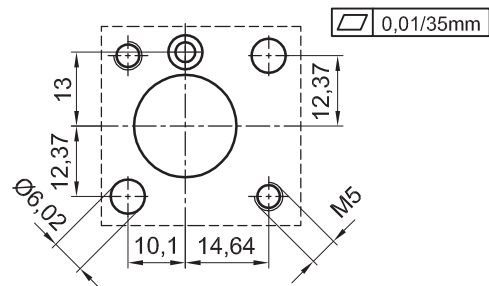

Please specify Pressure, RPM, Temperature, Gain and the Duty Cycle by ordering!



**Jung-Fluidtechnik GmbH**  
Mohrenstrasse 7  
D-76275 Ettlingen

**Phone** +49 (0) 7243-14648  
**Fax:** +49 (0) 7243-17996  
**E-Mail:** info@jung-fluid.de

Data Sheet  
**IPZ 0 - HER3**  
subject to modifications