

Reversal Pump IPZ 1 - HRL10-S Standard with 0,60 ccm/RPM

Standard Design with Separate Leakage Oil Connection (L)
(Customized Design on Request)

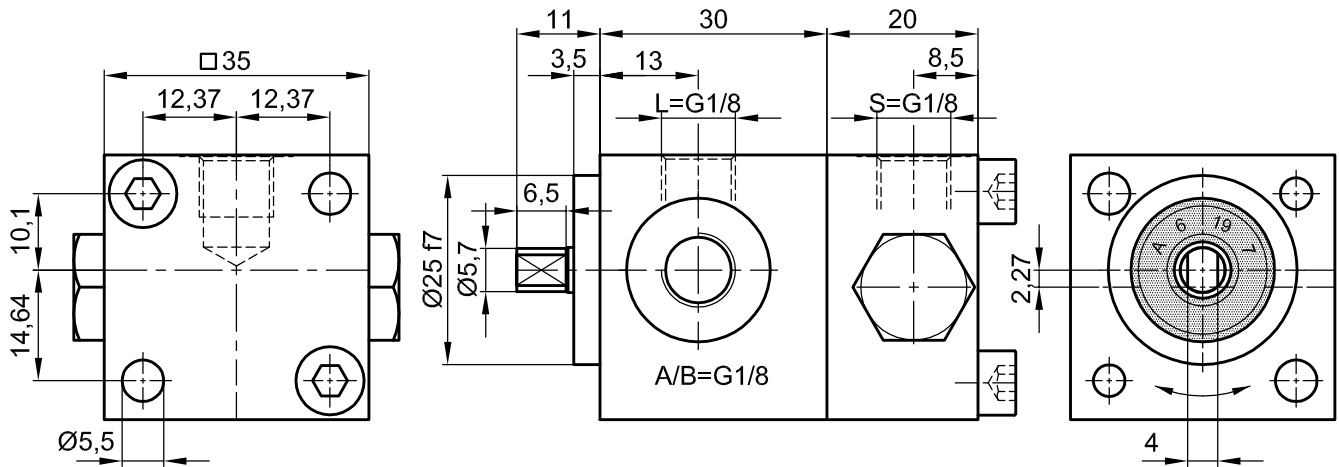

Mounting: DIN 912-M5x60-8:8, Tightening Torque: 8 Nm

Symbol:

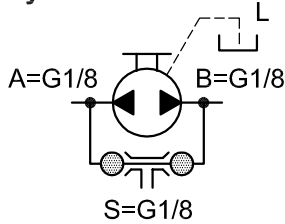

The technical data are based on a viscosity of 46 sq mm/s

ccm/ rpm	Press./bar max.		RPM max.		RPM min.	Mass	Order No.
	P1	P max	Press. P1	Depress.	Press. P1		
0,60	75	100	4000	5000	1000	430 g	10028-142

P1 = Working Pressure max. P max. = Pressure Peak

Working Pressure / bar							
Capacity at 1.500 RPM (l/min)							
Power Consumpt./W at 1.500 RPM							
bar	10	20	40	60	80	100	120
l/min	0,89	0,88	0,85	0,80	0,73	0,65	0,56
Watt	30	60	120	180	240	300	360

Working Pressure / bar							
Capacity at 3.000 RPM (l/min)							
Power Consumpt./W at 3.000 RPM							
bar	10	20	40	60	80	100	120
l/min	1,79	1,78	1,75	1,70	1,63	1,55	1,45
Watt	60	120	290	360	480	600	720

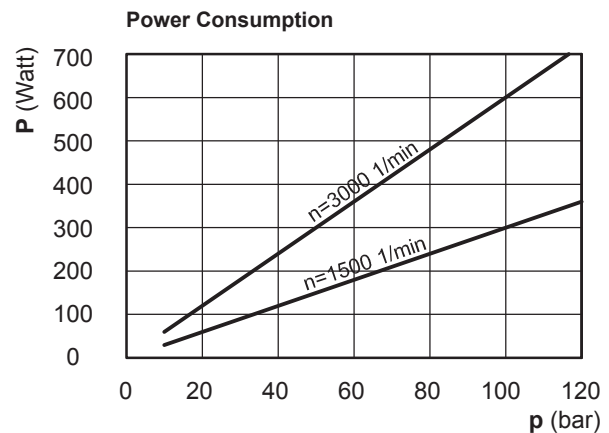
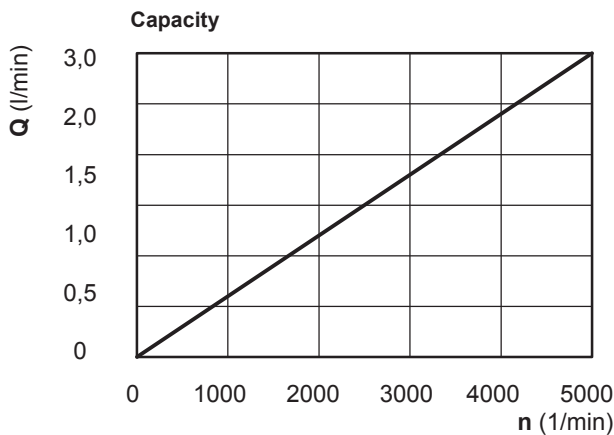

Please specify Pressure, RPM, Temperature, Gain and the Duty Cycle by ordering!



Jung-Fluidtechnik GmbH
Mohrenstrasse 7
D-76275 Ettlingen

Phone +49 (0) 7243-14648
Fax: +49 (0) 7243-17996
E-Mail: info@jung-fluid.de

Data Sheet

IPZ 1 - HRL10-S
subject to modifications